

XHDATA D-808

FM Stereo/LW/MW/SW-SSB AIR RDS

Digital Signal Processing Receiver

A User's Manual

By Kevin Davidson

Illustrations by XHDATA









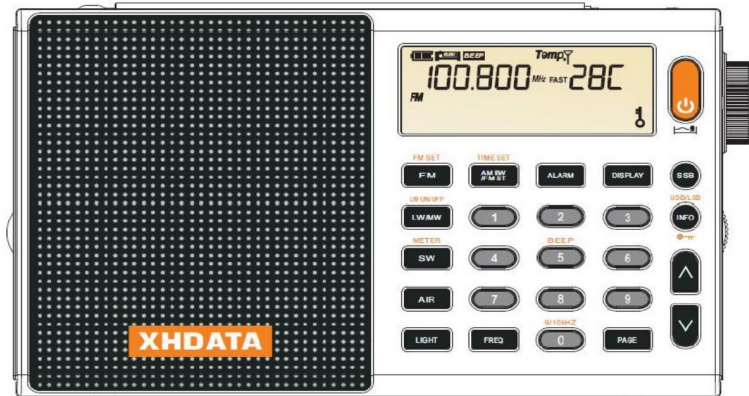

















Table of Contents

Radio - Front View	3
The Display	4
Side Controls	5
Radio Rear	6
Warnings	7
Quick Start Guide	7
Functions and Operation	8
Power and Charging	8
Power on Button and Sleep Timer	8
Alarms	8
Charging the Radio	9
Operations and Setup	9
FM Tuning Range	9
Longwave Setup	9
Medium Wave step	9
Beep	9
Temperature	10
Setting the Clock	10
Lock	10
Display Light	10
Memory System	11
Auto Tune Storage (ATS)	11
Antennas	11
Display Mode	12
Bandwidth	12
Tuning Speed	12
FM Reception	13
FM RDS (radio data system)	13
MW (medium wave)	14
LW (longwave)	14
SW (shortwave)	15
Single Sideband (SSB)	16
AIR Band	16
Squelch	17
Reset	17
Specifications	18

RADIO – FRONT VIEW



-  FM Band select / ATS / Set FM Range
-  MW/LW Band select / ATS / Enable LW
-  SW Band select / AT S / scroll through Meter bands
-  Air band select / ATS
-  Display light on/off
-  AM Bandwidth / FM Stereo / Time set
-  Number 1 Frequency / Page / Memory
-  Number 4 Frequency / Page / Memory
-  Number 7 Frequency / Page Memory
-  Frequency entry follows
-  Display option: Clock, Alarm, Signal strength, Temperature
-  Number 3 Freq. / Page / Memory / Temp scale setting
-  Number 6 Frequency / Page / Memory
-  Number 9 Frequency / Page / Memory
-  Memory Page selection

-  Power / Sleep timer
-  Single Sideband (SSB)
-  Upper/Lower Sideband select / RDS Info / Lock
-  Frequency up / scan
-  Frequency down / scan
-  Alarm on / Alarm set
-  Number 2 Frequency / Page / Memory
-  Number 5 Frequency / Page / Memory / Beep set
-  Number 8 Frequency / Page / Memory
-  Number 0 Freq / Page / Memory / 9/10 kHz MW step select

The Display

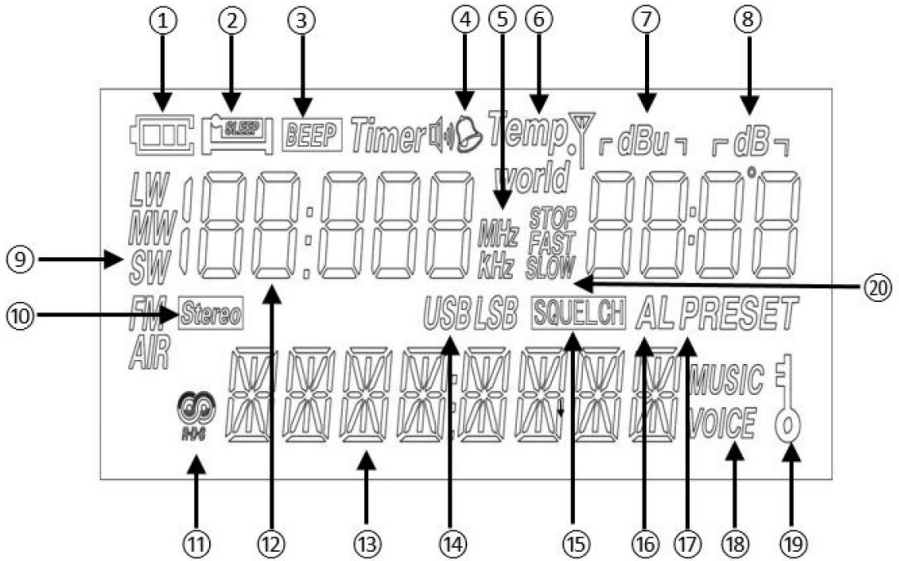

- | | |
|------------------------------------|-----------------------------------|
| 1. Battery charge indicator | 11. FM RDS available |
| 2. Sleep timer active | 12. Frequency |
| 3. Key press beep active | 13. RDS Information |
| 4. Alarm on | 14. USB / LSB mode |
| 5. Frequency Display is kHz or MHz | 15. Squelch active on signal |
| 6. Display temperature mode | 16. Alarm active |
| 7. Signal strength | 17. Display shows Memory location |
| 8. Noise level | 18. Not available on this radio |
| 9. Band selection | 19. Radio keys locked |
| 10. FM Stereo signal | 20. Tuning knob speed |

Side Controls

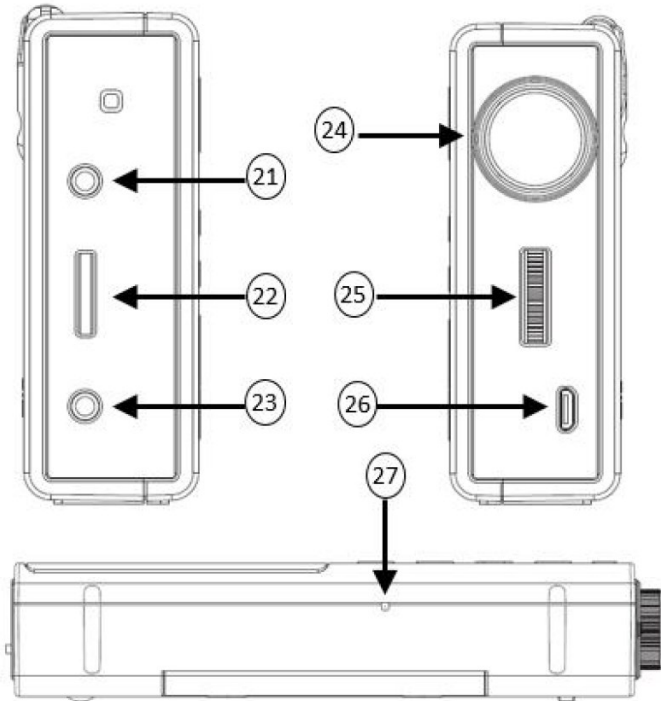

- 21. External Antenna Jack (3.5mm)
- 22. Volume control
- 23. Headphone jack (3.5mm stereo)
- 24. Main Tuning knob (push in for fast/slow/stop)
- 25. Fine tuning / clarify control for SSB
- 26. USB Charging port
- 27. Radio reset button access hole

Radio rear

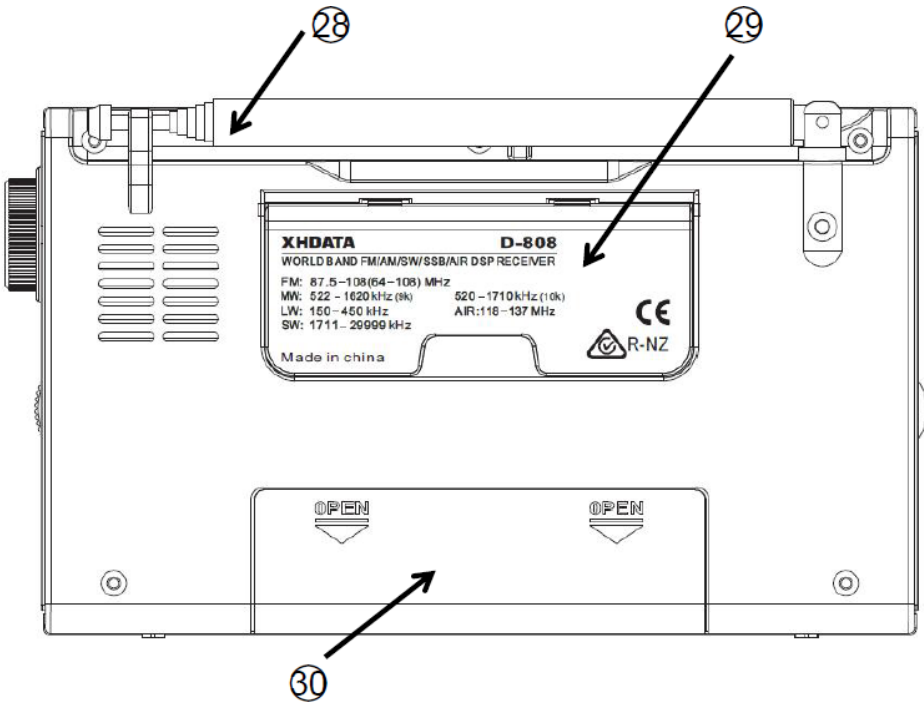

28. Whip antenna used for FM, SW and AIR bands

29. Kickstand

30. Battery door (18650 battery included)

Warnings

- Do not expose the radio to water, moisture or excessive humidity.
- Keep radio out of the freezer. Operating temperature range is 0° - 40° C (32° - 104° F).
- Clean with a dry cloth. Don't use detergents or chemical solvents.
- Do not attempt to open the unit, unless you are really curious. You might break something.
- Replace the battery within one minute to avoid loss of time and other settings.

Quick Start Guide

1. The radio is shipped with a protective tab in the battery compartment that prevents the battery from contacting the battery terminal. Carefully remove the battery door (back of radio) and remove the battery and the tab. Replace the battery taking care to align the polarity of the battery (+/-) to match the diagram on the back of the radio. Replace the battery door.
2. Turn the radio on by pressing the orange power button on the upper right corner of the radio.
3. Select a radio band — FM, MW, SW or AIR — then raise the volume with the knob on the left side of the radio. Increasing volume is in the upward direction.
4. Tune the radio by rotating the tuning knob on the upper right side of the radio. Clockwise is increasing frequency. To tune to a station directly, press the **FREQ** button, then the frequency. If the radio does not tune to the frequency, press **FREQ** again to complete the entry.

In this manual, the terms “press” and “long press” are used. Press means to press the button briefly. Long press means to press the button and hold it for 2 seconds. When making settings, wait a few seconds after making the setting and the radio will save the setting and exit setting mode.

Functions and Operation

Power and charging

Power On Button and Sleep Timer

The orange power on button turns the radio on and the sleep timer icon will flash in the display for 5 seconds. While the sleep timer icon is flashing, further presses of the Power button increment through a list of sleep times from 120 to 15 minutes or “on” indicating the timer is disabled. When the sleep timer is set, the radio will automatically power off after the selected number of minutes. The radio cannot be turned off while the sleep timer icon is flashing — just wait until it stops.

The sleep timer can be canceled by simply turning the radio off or long-press the power button to re-enter the sleep timer setting mode.

Alarms

The radio can automatically power on based on the alarm setting. Alarm mode can be set on or off with the ALARM button.

To turn the alarm on or off, turn off the radio and press the ALARM button. Use the up arrow key to toggle through the three alarm modes: Wake to radio, wake to tone and off. The alarm mode is indicated on the display with a tiny speaker symbol to the right of the word “Timer” for wake to radio, a tiny bell to indicate wake to tone, or no symbol when the alarm is off. Wake to radio uses the most recently tuned station.

To set the alarm time, long-press the ALARM button and key in the time with the number buttons. For example, to set the alarm for 21:30, long press the ALARM button and key 2 1 3 0. The alarm is set at the factory for 7:00 AM, turned off. The radio does not support a 12-hour clock.

Charging the radio

To charge the radio, plug the included cable into the USB-C jack on the right side of the radio. (Some early versions of the radio use a USB Micro connector.) The battery icon will cycle while the radio is charging. Charging will stop when the battery is fully charged or after 10 hours, whichever is first. Some chargers with USB -C output require a protocol that will not work with this radio; it is recommended to use a USB-A to USB-C cable (like the included one) to charge the radio.

Options and setup

FM Tuning range

The radio can be set for different tuning ranges that are convenient for FM broadcasting in different regions of the world. With the radio off, long-press the FM button. The current setting, showing the lowest frequency of the band, is displayed. To change the setting, press the FM button again to cycle through the three options:

- 64.0 MHz
- 76.0 MHz
- 87.5 MHz

Longwave

The LW band is not enabled by default. To enable it, turn the radio off and long-press the LW/MW button. The radio will display the current status of the setting, “LW ON” or “LW OFF.” To change the setting, short press the LW /MW button again. When LW is enabled, pressing the LW/MW with the radio on toggles between the LW and MW bands. When disabled, the LW option is not available.

Medium Wave Step

The tuning step for medium wave (MW) can be set for 9 kHz or 10 kHz. To change the setting, turn the radio off and long-press the 9/10 kHz button (0). The current setting is displayed. Press the button again to cycle through the two options. 10 kHz is used in the Americas and 9 kHz in the rest of the world.

Beep

The radio as it comes from the factory beeps after each key press. To disable this,

turn the radio off and long-press the BEEP button (5). Unlike other options, multiple presses of the button do not toggle the option. Long press the key to change it.

Temperature

The temperature scale for display, Fahrenheit or Centigrade, may be selected. With the radio off, repeatedly press the DISPLAY button until the temperature is displayed, then long-press the number 3 to change the setting. Repeatedly press the button to toggle between F and C.

Setting the clock

The radio clock supports 24-hour time display only.

The radio has the option to automatically set the time from an FM broadcast station that provides it (refer to the RDS topic for more on this). To enable automatic setting, press the TIME SET button with the radio off. Use the up arrow key to toggle between Auto and Manual modes. Note: many FM stations do not broadcast time, and those that do may not be accurate. You must manually tune the station with time information for the time to be set from RDS.

To set the clock manually, make sure the time mode is Manual, turn the radio off and long press TIME SET. The radio will display "TIME." Key in the 4-digit time to set. To set the seconds to 00, wait until about 7 seconds before the 00 minute, then activate the time function, quickly key in the time and then press TIME again. Note that time setting mode automatically exits after about 4 seconds with no key pressed.

Lock

With the radio on or off, long press the INFO button to disable the keys on the radio. Long press again to re-enable them. This feature is useful to prevent the radio from being turned on accidentally during handling or when packed.

Display light

The display is automatically illuminated for about 10 seconds when you press a key or turn the tuning knob. Pressing the LIGHT button turns it on indefinitely. When set, the light stays on even when the radio is turned off. Press LIGHT again to turn the display illumination off.

Radio operation

Memory System

This radio has 500 memory locations, 100 for each band, organized into 10 pages with 10 memory locations each. A memory location stores the station frequency along with the stereo setting for FM and the bandwidth for LW/MW/SW.

Select the desired band (MW, LW, FM, SW or AIR) first. Then to save or retrieve a station in memory, first establish the current memory page by pressing the PAGE button and then pressing the page number button (0-9).

Once a page is selected, a frequency is stored to a memory location within the page by long-pressing the position number button (0-9). To recall a saved station, just press the number button (0-9) of the memory position within the current page.

Auto Tune Storage (ATS)

This radio has the capability to scan the bands and automatically store stations into memory. It loads them sequentially by page, and by position within the page, overwriting any previously stored stations. ATS is invoked by first selecting the band and then with a long press of the band button, FM, LW/MW, SW or AIR. ATS stores relatively stronger stations and may skip some that are barely audible. Also, particularly on shortwave, the signal may fade in and out, causing the station to be skipped. AIR transmissions are often short and may not be active when the radio scans a particular frequency.

Note that for shortwave, the radio only scans within the international broadcast frequencies, not amateur radio or commercial bands. Refer to the SW topic.

Antennas

Antennas capture radio signals that are processed by the radio. This radio has 3 antenna options:

- Internal ferrite bar antenna used for LW/MW
- A 25.5" telescopic whip antenna for SW/FM/AIR
- A 3.5mm jack to connect an external antenna of your choice for SW/FM/AIR.

Caution: Ensure that an external antenna is clear from power lines.

The internal ferrite bar antenna is directional. Physically turn the radio for best reception. You may find that moving the radio to a different location, even slightly, greatly improves reception on all bands.

AM reception can often be improved by placing a passive loop antenna next to the radio. Even 10-20 feet of wire can make a big difference on shortwave.

Display Mode

The display can be set to show different information; press the DISPLAY button to cycle between signal strength/signal to noise ratio, time, temperature and alarm time.

Signal strength is expressed in dBu units, the larger the number, the stronger the signal. The signal to noise ratio is expressed in dB units; the larger the number, the greater the signal quality, with a value of 0 indicating that signal and noise are equal. The value is also shown as 0 when there is no signal at all.

Bandwidth

While radio signals are centered on one frequency, they actually occupy a range of frequencies. Sometimes two stations with adjacent frequencies can interfere with each other. This problem can be lessened by reducing the frequency range (bandwidth) the radio tunes. This feature is available on LW, MW and SW on this radio, but typically only used on SW. The bandwidth is selected by pressing the AM BW button. The width is shown on the display, and repeated presses of the button will cycle through the values: 6, 4, 3, 2.5, 2, 1.8 and 1 kHz. The bandwidths in SSB mode are 4, 2, 2.2, 1.2, 1, and 0.5 kHz. Generally, the higher the bandwidth, the better the audio fidelity and the lower the bandwidth, the lower the interference and noise.

Tuning speed

The tuning knob has FAST, SLOW and STOP modes. Switch between them by pressing the tuning knob in towards the radio. The display shows the mode in small print.

- FAST - advance 5 kHz (3 kHz on LW, 9/10 kHz on MW, 25kHz on AIR and 100 kHz on FM)
- SLOW - advance 1 kHz (10 kHz on FM)

- STOP - does not advance

FM Reception

To receive FM broadcasts, fully extend the whip antenna and press the FM button. Here are your tuning options:

1. Press **FREQ**, enter the frequency of the station, and press **FREQ** again.
2. Long press the **FM** button to activate **ATS** to store all strong stations into memory (see section on the **Memory system** for how to access them).
3. Press the up or down arrow keys to go to the next frequency.
4. Long press the up or down arrow to scan for the next strong station.
5. Rotate the tuning knob to tune stations.

Some FM stations broadcast in stereo. In this case, **STEREO** appears on the display. Listening to the two stereo channels requires stereo headphones. Stereo can be turned off and on with the **FM ST** button. It may be automatically disabled for a weak signal. In some situations, you may get improved reception by turning stereo off. The stereo setting is stored in the station memory when the frequency is saved.

FM RDS (radio data system)

RDS is a means for FM radio stations to transmit data along with their programming. Not all FM stations employ RDS, but the ones that do typically transmit the station name, the station type, the song artist and title when playing music, and occasionally the time. When RDS is present, the RDS icon on the display is shown and the RDS data information appears at the bottom of the display. Use the **INFO** button to cycle through the RDS data options. This radio supports the following RDS information:

- **PS**—Program Service Name
- **DATA**—Date (“NO DATE” if not present)
- **PTY**—Program type: News, Drama, Rock music... (“NONE” if not present) These values are not correct in North America
- **RT**—Radio Text may contain artist and title information for music (“NO RT” if not present)

RDS date information can be used to automatically set the radio clock. Refer to the Clock Setting topic for additional information.

MW (medium wave)

To receive MW broadcasts, press the LW/MW button. Here are your tuning options:

1. Press **FREQ**, enter the frequency of the station, either 3 or 4 digits.
2. Long press the LW/MW button to activate ATS and store all strong stations into memory (see section on the Memory system for how to access them).
3. Press the up or down arrow keys to go to the next frequency.
4. Long press the up or down arrow to scan for the next strong station.
5. Rotate the tuning knob to tune stations.

Rotate the radio for the best reception. Refer to the Antenna topic for more information.

LW (longwave)

Longwave reception is not enabled from the factory. Refer to the Settings topic for how to enable it. Pressing the LW/MW button when longwave is enabled switches between the two bands. The display shows which is selected.

Here are your tuning options:

1. Press **FREQ**, enter the frequency of the station.
2. Long press the LW/MW button to activate ATS to store all strong stations into memory (see Memory system topic for how to access them).
3. Press the up or down arrow keys to go to the next frequency.
4. Long press the up or down arrow to scan for the next strong station.
5. Rotate the tuning knob to tune stations.

Rotate the radio horizontally for the best reception. Refer to the Antenna topic for more information.

SW (shortwave)

Fully extend the whip antenna and press the SW button to select the shortwave function and tune to the previously accessed shortwave frequency. Repeated presses of the button cycle through the 14 international shortwave broadcast bands. The display shows which meter band is selected briefly after the button is pressed. The bands are:

- 120m (2300 - 2495kHz)
- 90m (3200 - 3400 kHz)
- 75m (3900 - 4000 kHz)
- 60m (4750 - 4995 kHz)
- 49m (5730 - 6200 kHz)
- 41m (7100 - 7450 kHz)
- 31m (9250 - 9900 kHz)
- 25m (11500 - 12100 kHz)
- 22m (13570 - 13870 kHz)
- 19m (15300 - 15830 kHz)
- 16m (17480 - 17900 kHz)
- 15m (18900 - 19020 kHz)
- 13m (21450 - 21850 kHz)
- 11m (25670 - 26100 kHz)

Note: The band ending frequencies are approximate.

Here are your tuning options:

1. Press **FREQ** and enter the frequency of the station. You may need to press **FREQ** again to complete.
2. Long press the **SW** button to activate **ATS** to store all strong stations into memory (see **Memory System** topic for how to access them). Note that only the stations within the 14 international shortwave bands are scanned.

3. Press the up or down arrow keys to go to the next frequency.
4. Long press the up or down arrow to scan for the next strong station. Note that only the 14 international shortwave bands are scanned.
5. Rotate the tuning knob to tune stations.

Position the radio for the best reception. Refer to the Antenna topic for more information.

Single Sideband (SSB)

SSB is a transmission method used by amateur radio and commercial radio services. It reduces the power requirements and improves reception, but it requires special receiving equipment. Most voice transmissions on the amateur radio bands are SSB, and can be recognized by a highly distorted and punctuated sound for voice.

To receive SSB on this radio, first tune the station as accurately as possible. Then press the SSB button. After some delay, the display will show the sideband setting, either upper sideband (USB) or lower sideband (LSB). In SSB mode, the INFO button switches between the two sidebands. LSB is most often used for frequencies below 7300 kHz and USB for those over 14000 kHz, *with exceptions*.

Use the fine tuning knob (+/- 990 Hz in 10 Hz steps) on the right side of the radio for the best sound. Be patient; SSB tuning takes practice.

Press the SSB button again to exit SSB mode. The radio will display "NORMAL."

Refer to the Bandwidth topic for how to improve shortwave reception.

AIR Band

To receive aviation transmissions, fully extend the whip antenna and press the AIR button. Here are your tuning options:

1. Press FREQ, enter the frequency of the station, and press FREQ again if necessary.
2. Long press the AIR button to activate ATS to store all strong stations into memory (see section on the Memory system for how to access them).
3. Press the up or down arrow keys to go to the next frequency.
4. Long press the up or down arrow to scan for the next strong station.

5. Rotate the tuning knob to tune stations.

Air band is best received near airports. Look up the approach frequency for your closest airports online and store them in the Air band station memory locations; refer to the “Memory System” topic on how to store frequencies.

Reset

Should the radio become inoperable, you may attempt to reset the radio by pushing a small object such as a toothpick or paperclip into the Reset hole until you feel a click. Take care not to press too hard and damage the radio.

Squelch

This radio has a special feature called “squelch.” When set, the radio remains muted (silent) until a transmission stronger than the set level is received. To activate the feature, long press the tuning knob in towards the radio until the word “Squelch” appears on the display, then *immediately* (you have less than a second to begin setting) rotate the tuning knob to set the squelch level. The values are 1-9 and OFF. Increasing the number increases the necessary signal level for the radio to activate. As you turn the knob towards higher numbers, you will hear the signal drop off at some point. The optimum level is usually the highest number without background noise. After selecting the level, just wait a second or two and the radio will exit setting mode.

When the radio is muted due to a weak station, the SQUELCH indicator appears in the display.

Turning squelch off may enable reception of weak signals that would otherwise not be heard. A single squelch setting is used for all bands, so it may be desirable to reset the level or disable it when switching bands.

Caution: Setting squelch to a very high level will result in the radio not receiving any stations and appearing non-functional.

Specifications

Radio bands

- FM: 64 - 108 MHz
- MW: 520 - 1710 kHz
- SW: 1711 - 29999 kHz
- LW: 150 - 450 kHz
- AIR: 118 - 137 MHz

Sensitivity:

- FM: < 3 μ V
- MW: < 0.5 mV/m
- LW: < 10 mV/m
- SW: < 10 μ V
- AIR: < 0.5 μ V

AM Selectivity: > 80dB

Number of memories: 500 (100 per band)

Battery: 1 x 18650

DC input voltage: 5V

Power consumption : 140 μ A off, 120 mA at maximum volume

Speaker: 8 Ω 1 W

Earphone Jack: 3.5mm stereo

Dimensions: 157(W) x 92(H) x 32(D) mm

Weight: 265g (without battery)

Accessories: Earphone, storage bag, external antenna, USB-C charging cable, 18650 battery, and English user manual

Notes

